

The Weakest Link:

Exposing the Dangers of Non-Compliant RJ45 Connectivity

By members of the New Technology & Trends Committee



Introduction

The 8-position 8-contact (8P8C) modular connector, commonly known as the RJ45, is a highly engineered interconnection system of jacks and plugs with eight equally spaced contacts. Though its history began in the 1960s for telephony, the RJ45 achieved widespread adoption with the rise of Ethernet networking over twisted-pair cabling. Renowned for its backward compatibility and interoperability, the RJ45 is now the world's most ubiquitous copper interface for network equipment and device connections — from the International Space Station 250 miles above Earth to submarines exploring the ocean's depths, and everywhere in between.

Industry standards define the physical, mechanical, and material specifications of the RJ45 interface, as well as its safety requirements and performance parameters. With Ethernet speeds at 10 Gbps and power over Ethernet (PoE) delivering up to 90W of DC power, compliance is more crucial than ever. Substandard RJ45s can compromise links that utilize even the best cable, making them the network's potential weakest link. Non-compliant RJ45 connectivity is alarmingly prevalent, which not only degrades network performance and causes costly downtime but also poses a risk to people and property.

This paper is a cooperative effort by members of the Communications Cable & Connectivity Association (CCCA; www.cccassoc.org). Together, these members manufacture quality, standards-compliant RJ45 connectivity solutions and work to educate the ICT industry about the risks of non-compliant, substandard components in the market. This paper describes the key industry standards that RJ45 connectivity should comply with, the dangers of non-compliance, and how Integrators who deploy these solutions can best protect themselves, their customers, and the general public.



TIA-1096-A: The Gold Standard for RJ45 Plugs and Jacks

ANSI/TIA-1096-A, *Telecommunications Telephone Terminal Equipment Connector Requirements for Connection of Terminal Equipment to the Telephone Network*, defines RJ45's physical dimensions, mechanical characteristics, and contact material requirements. This includes tolerances for plugs and jacks, such as height, width, minimum plug and tab length, contact area, size, and spacing. The standard also specifies plug-jack contact requirements, including:

- **Contact angle:** The angle between the plug and jack contacts when latched
- **Mating force:** Peak in-line force during insertion until the latching tab locks
- **Removal force:** Peak in-line force during plug removal with the latching tab unlocked
- **Draft:** Slight angle on plug and jack surfaces to enable easy insertion and removal

These specifications ensure the RJ45's interoperability and proper mating, maintaining a reliable electrical connection and preventing damage. For instance, the standard specifies a contact spacing of 1.02 mm (0.040 in.) and a crimp height of 6.01 mm \pm 0.12 mm (0.237 in. \pm 0.005 in.), which is critical for the insulation-piercing contacts (IPC) to align correctly with the jack contacts. A contact angle of 13 to 24 degrees between plugs and jacks is also specified to prevent signal loss and physical interference.

A key aspect of TIA-1096-A is the material requirements. The standard requires the base layer of RJ45 contacts to be phosphor bronze for its durable and stable physical and mechanical properties. The standard further mandates a hard gold-to-hard gold contact interface, leveraging gold's excellent conductivity and corrosion resistance. It also specifies a hardness value to ensure durability across multiple insertion/removal cycles and prevent brittleness in cold environments.

Specifically, the gold plating of contacts must meet the following criteria:

- Minimum 99% pure gold (24 carat), with a minimum density of 17 grams/cm³
- Minimum gold thickness of 50 micro inches (μ in)
- A Knoop hardness (HK) ranging from 130 to 250 measured according to ASTM E384-05a using a load force of 0.245 N (25 g)
- Absence of corrosion products exceeding 0.05 mm (0.002 in) in diameter when tested for porosity and other surface defects per EIA-364-53B

TIA-1096-A also requires a 99.5% pure nickel barrier of at least 50 μ m in thickness between the gold surface and the phosphor bronze base of the plug and jack contacts. This barrier is crucial for preventing the underlying metal from migrating through the gold plating and causing corrosion while also enhancing gold adhesion and protecting the softer phosphor bronze. The standard does not mandate a specific plating process, provided all requirements are met.

Additionally, TIA-1096-A requires a smooth, burr-free surface at the contact interface, with a maximum surface roughness of 32 μm . The standard also specifies a minimum contact force of 0.98 N (100 g), which represents the pressure exerted between the jack and plug contacts by the jack contact's spring force. Figure 1 illustrates key TIA-1096-A specifications for the RJ45 connector.

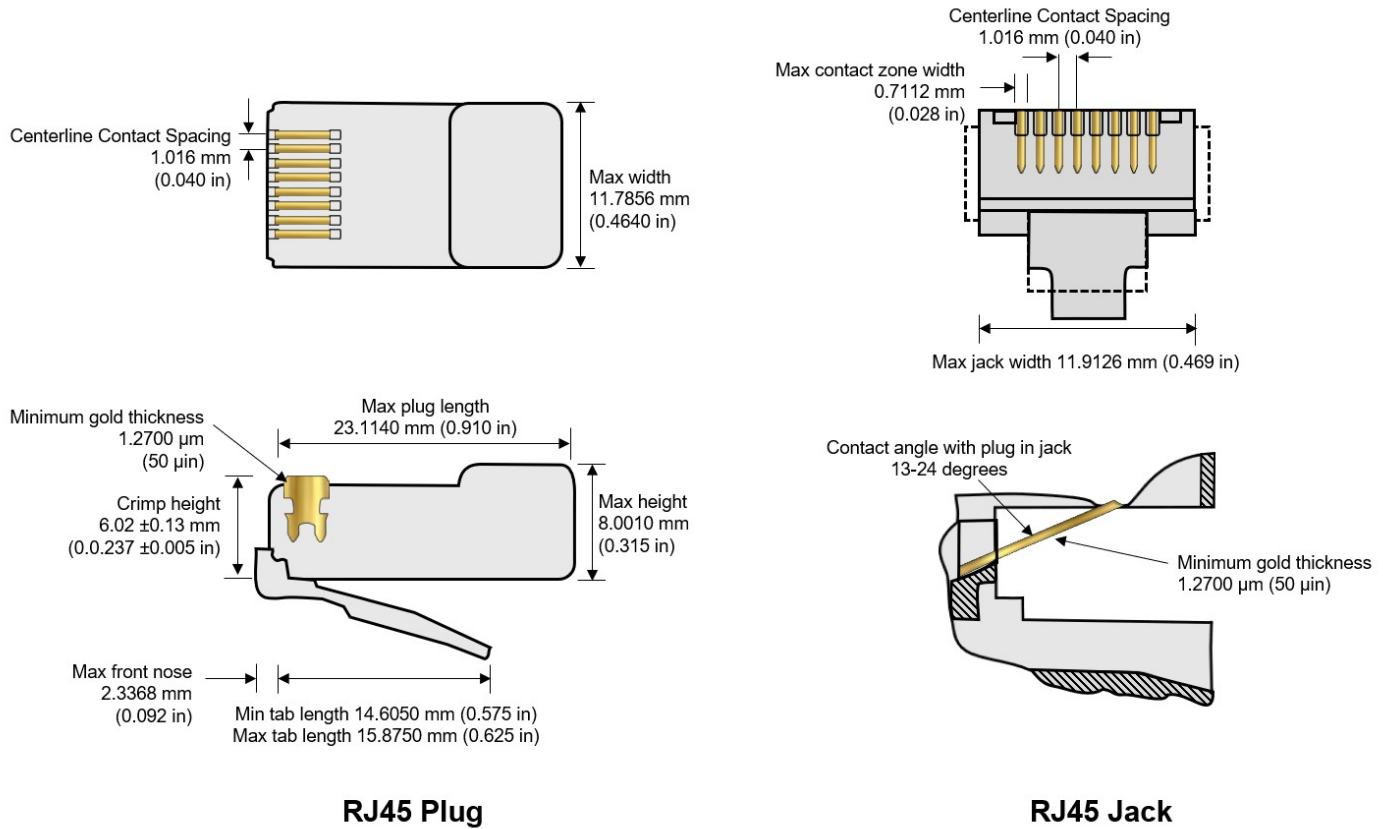

Figure 1: TIA-1096-A defines physical dimensions, mechanical characteristics, and contact material requirements for RJ45 plugs and jacks.

From an international perspective, IEC 60603-7, *Connectors for Electronic Equipment - Part 7*, aligns with TIA-1096-A in terms of physical dimensions, mechanical characteristics, and contact material requirements for the RJ45. IEC 60603-7 also establishes operating and climatic temperature limits, as well as high-frequency performance requirements for connectors operating at frequencies of up to 100 MHz, 250 MHz, and 500 MHz. For example, it specifies a maximum allowable resistance of 20 milliohms ($\text{m}\Omega$) between mated connectors. IEC 60603-7 also specifies mechanical operations requirements for minimum mating cycles without exceeding a 20 $\text{m}\Omega$ increase, including 750 cycles for performance level 1 components and 2500 cycles for performance level 2 components.

Hidden Dangers: The Risks of Non-Compliant RJ45s

Adherence to the physical dimensions, mechanical characteristics, and contact material requirements defined in TIA-1096-A is crucial for the interoperability and signal integrity of RJ45 plugs and jacks. Unfortunately, the market is showing a concerning increase in non-compliant RJ45 connectors, particularly from unknown manufacturers that prioritize cost minimization. These substandard RJ45 plugs and jacks pose significant risks.

Material and Plating Problems

A prevalent issue is the use of inferior materials and plating processes. Since gold constitutes most of an RJ45 connector's cost, it is a common target for cost reduction. Investigations often reveal RJ45 connectors with contact gold purity below 99% (24 carat) and/or plating thickness less than the required minimum of 50 μin . This can lead to oxidation and corrosion, resulting in intermittent or permanent signal loss. While X-ray fluorescence can measure plating thickness, verifying material compliance to TIA-1096-A requires an independent third-party metal testing lab capable of measuring purity, Knoop hardness, and corrosion.

Beyond material composition, inferior quality control can manifest as variations in plating thickness across contacts and out-of-spec surface roughness. While some manufacturers use electropolishing to achieve a smooth, uniform contact surface before plating, others opt for a less expensive mechanical wire brushing method that can yield a more variable surface finish. Extreme instances of inferior quality can result in embedded contaminants, flakes, and microdefects. These

defects lead to inconsistent plating thicknesses and can cause gold to wear off the jack contact surface after as few as 10 to 15 insertions and removals, resulting in signal degradation or loss.

Electropolished RJ45 Contact

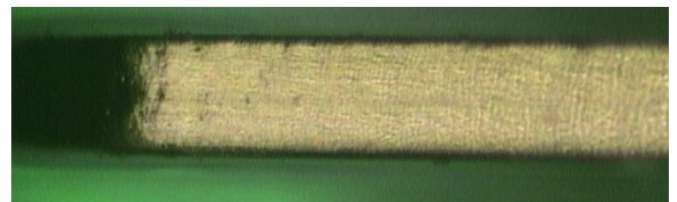

Poor Quality Wire Brushed RJ45 Contact

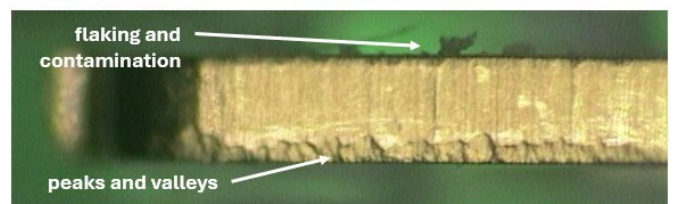

Figure 2: Electropolishing contacts before plating achieves a smooth, uniform surface, while in extreme cases, mechanical wire brushing results in a variable surface finish with flakes, contaminants, and peaks and valleys that can prohibit proper gold plating and lead to corrosion.



Dimensional Deviations

Precise dimensions for both jack and plug, as outlined in TIA-1096-A, are critical for ensuring proper interoperability and functionality.

- **Housing Dimensions:** If plug housings are too small or jack housings are too large, excessive play can occur, causing plug contacts to lift from jack contacts and leading to intermittent signal loss. Conversely, oversized plugs or undersized jacks require excessive force for insertion/removal, which can damage the connector. Superior manufacturing quality control is vital to ensure consistency and prevent dimensional fluctuations.
- **Contact force:** Maintaining the contact force is critical to prevent electrical discontinuity, especially in high-density patching environments where adjacent connectors can be disturbed, or in settings with vibration or thermal cycling.
- **Contact Geometry:** Correct spacing, size, and depth of contacts are essential. Non-compliant RJ45 connectors often exhibit blade depth issues, failing to meet the specified crimp height of $6.01 \text{ mm} \pm 0.12 \text{ mm}$ ($0.237 \text{ in.} \pm 0.005 \text{ in.}$). Blades set too low risk not making contact, while those set too high can cause increased wear on the contacts, and in extreme cases, deformation of the jack contacts. Out-of-spec jack contact angles are also problematic: an angle that is too steep can reduce the contact area, while one that is too shallow can interfere with the plug housing.
- **Latch Geometry:** The plug's latch geometry is critical for ensuring the correct contact position. Insufficient latch height or depth can prevent the locking mechanism from functioning correctly, leading to electrical discontinuity if manipulated. A latch that is too high or too deep can make plug removal difficult, causing user frustration and potentially deforming the latch.

A BRIEF HISTORY OF THE RJ45

The RJ45 connector's origins trace back to the late 1960s at Western Electric, the manufacturing arm of the Bell Operating Companies. A team led by Edwin Hardesty conceived the design to develop a cost-effective, four-conductor telephone handset connector that is easy to disconnect. The original telephony plug used voice-grade stranded tinsel conductors and featured 150 micro inches (μin) of gold on the contact blade.

The Judge Greene decision, which mandated the breakup of the Bell Operating Companies, profoundly influenced the RJ45's trajectory. In its wake, the FCC codified the RJ45 within Title 47 of the Code of Federal Regulations (CFR) Part 68 (FCC Part 68). This regulation established crucial technical standards for connecting terminal equipment to the public telephone network, ensuring network integrity and enabling informed consumer choices. It detailed the physical, mechanical, electrical, and material requirements of the RJ45 and other RJ series connectors, like the common RJ11 used for traditional landline connections.

Manufacturers had to register their products to comply with FCC Part 68. The "RJ" stands for Registered Jack, a term from the Bell System's Universal Service Ordering Code (USOC). In 2001, the FCC delegated registration to the Administrative Council for Terminal Attachments (ACTA), a process still used today for products interfacing with the public telephone network. Concurrently, the Telecommunications Industry Association (TIA) developed the TIA-968 standard, which outlined the technical criteria in FCC Part 68 and was adopted by the ACTA. In 2008, TIA moved the RJ45's mechanical and dimension specifications from TIA-968 and combined them with test procedures and material requirements into ANSI/TIA-1096-A, *Telecommunications Telephone Terminal Equipment Connector Requirements for Connection of Terminal Equipment to the Telephone Network*.

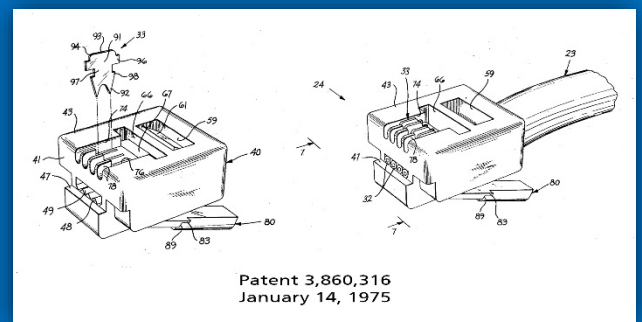

An Unforeseen Hazard: The Perils of Modern PoE Technology

RJ45 connectors were not initially designed for power delivery. However, since the introduction of PoE in 2003, the amount of power delivered along with data has significantly increased:

- **IEEE802.3af (2003):** Type 1 PoE, delivering a maximum of 15.4 W over 2 pairs (up to 13 W at the device).
- **IEEE802.3at (2009):** Type 2 PoE, delivering a maximum of 30 W of power over 2 pairs (up to 25.5 W at the device).
- **IEEE 802.3bt (2018):** Type 3 PoE, delivering a maximum of 60 W over 4 pairs (up to 51 W at the device), and Type 4 PoE, delivering a maximum of 90 W over 4 pairs (up to 71.3 W at the device).

RJ45 connectors that do not comply with TIA-1096-A are prone to increased resistance, oxidation, and poor plug-jack alignment. In PoE applications, these issues contribute to the formation of hot spots. In extreme cases, these hot spots can cause thermal runaway, an uncontrolled chain reaction of escalating heat generation and temperature. This can push temperatures beyond the maximum operating limits, potentially causing connectors to melt, damaging network equipment, or even initiating a fire.

A significant concern for all RJ45 connectors is the removal of plugs while under PoE load, which can produce an arc within the discharge area. This arc erodes the gold-plated contact surface, and corrosion migrates across the entire contact over time. Continuous unmating under PoE load can eventually cause plug and jack contacts to weld together. Reinserting a plug with corroded contacts can also cause the corrosion inside the jack to slough off, further degrading performance.

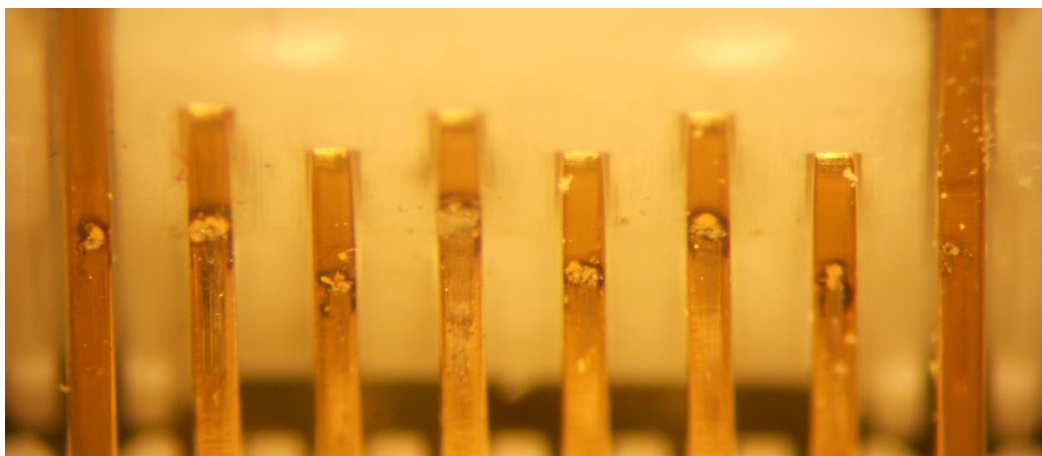

Figure 3: Unmating under PoE load causes an arc at the discharge area that can damage the plug and jack contacts.

The design of modern RJ45 connectors should prevent arcing from occurring within the nominal contact area, as corrosion in this area can lead to poor network performance, increased bit error rates, and even nonfunctional links.

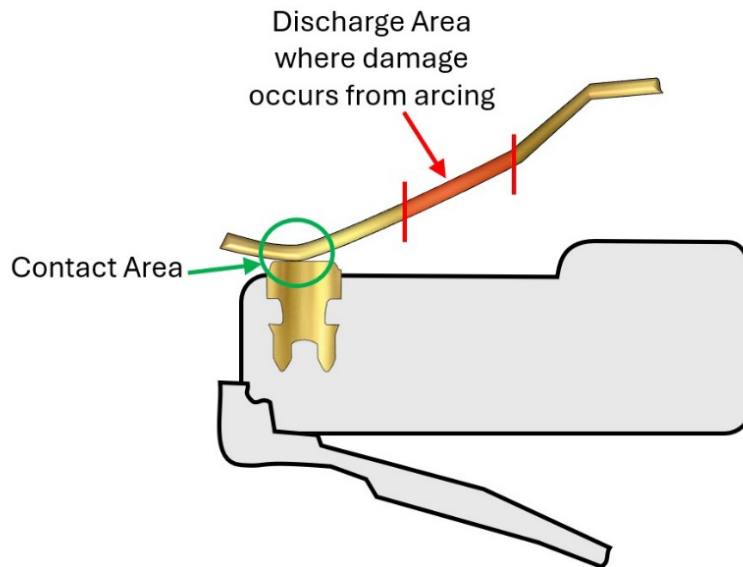
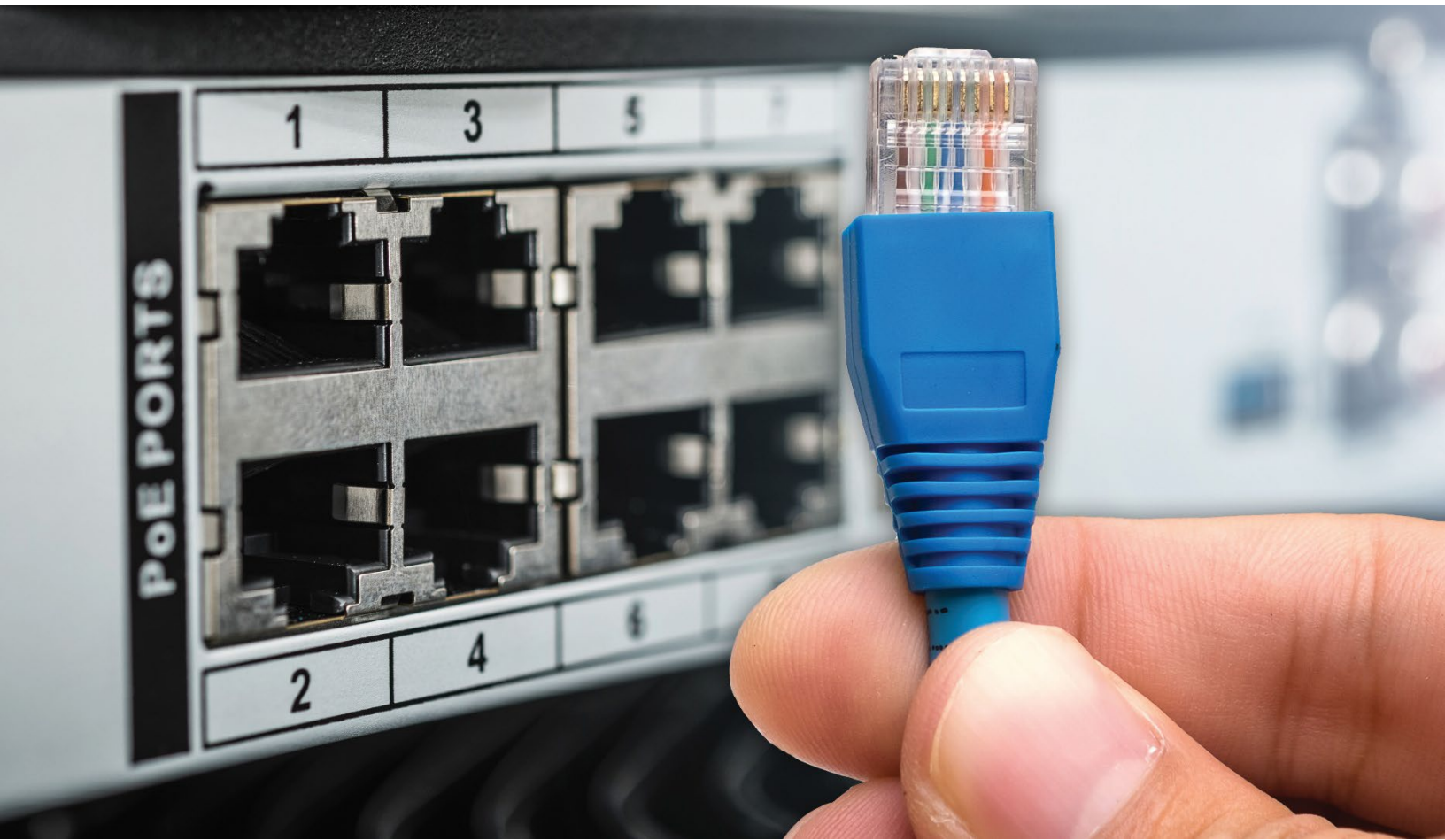

Figure 4: RJ45 connectors must ensure that damage from arcing remains in the discharge area and does not occur in the nominal contact area.

While no standard currently defines plug removal under PoE load, IEC 60512-99-002, *Connectors for Electrical and Electronic Equipment, Tests and Measurements*, provides testing guidance to ensure reliability when unmating under PoE load. The latest revision of IEC 60512-99-002 (Edition 2.1 2025-04) specifies that mated connections cannot exceed a resistance change of 20 m Ω after being subjected to 100 insertion and removal cycles under a load condition of 55V dc and 2000mA applied to each conductor.



Relevant UL Standards: Protecting People and Property

RJ45 connectors are also subject to various UL standards, as established by the global safety science leader UL Solutions. These include standards related to smoke density, flammability, and flame propagation.

UL 94: Flammability of Plastic Materials

A primary safety standard for RJ45s is related to the flammability of plastic materials used for plug and jack housing. UL 94, *the Standard for Safety of Flammability of Plastic Materials for Parts in Devices and Appliances*, tests the flammability of plastics, with V-0, V-1, and V-2 vertical burn ratings that indicate the material's ability to extinguish a flame after ignition. Of these three classifications, V-2 is the most relaxed, while V-0 is the most stringent.

RJ45s that only meet V-1 or V-2 ratings are non-compliant and at an elevated risk of contributing to the spread of flames in the event of a fire. This is especially a concern in PoE applications. When hot spots result in thermal runaway, UL 94V-0 materials play a crucial role in preventing the spread of flames.



Figure 5: The results of thermal runaway on Pins 7 and 8 caused by a non-compliant RJ45 jack. The use of UL 94V-0 materials allowed the plugs to self-extinguish, whereas materials of a lesser flame rating could have resulted in catastrophic flame spread.

UL 1863: Communications-Circuit Accessories

Another relevant standard is UL 1863, *Standard for Communications-Circuit Accessories*, which includes tests for impact, crushing, flexing, and pulling. UL 1863 requires a UL 94 flammability classification, stating that components using plastic

materials to enclose or support current-carrying parts must have a flame class of V-0. Therefore, RJ45 connectors listed to UL 1863 also meet the V-0 classification.

It's important to note that UL 1863 certification testing can use a dielectric withstand voltage of either 500 V RMS or 1000 V RMS. Connectivity tested to 500 V RMS can only safely support PoE voltage levels up to 42.4 V DC, while connectivity tested to 1000 V RMS can support voltage levels up to 353 V DC. Since many PoE-enabled devices like wireless access points, LED lights, and digital displays require more than 42.4 V DC, testing to 1000 V RMS is crucial. This higher rating ensures support for all PoE-enabled devices. Unfortunately, manufacturers with RJ45 connectors listed to UL 1863 may not necessarily specify the level of testing, so it is essential to choose products verified for PoE applications.

UL 2043: Products Installed in Air-Handling Spaces

UL 2043, *Standard for Fire Test for Heat and Visible Smoke Release for Discrete Products Installed in Air-Handling Spaces*, is a critical safety standard required by the National Electric Code (NEC®) and enforced by local building codes and authorities having jurisdiction. Commonly referred to as "plenum-rated," UL 2043 is required for components used in plenum spaces, which pose a higher fire risk due to air circulation.

RJ45 connectivity deployed in the plenum space must be plenum-rated to protect property and lives. Unfortunately, many commodity patch cords on the market are not plenum-rated, primarily because the cable used in the patch cord is not plenum-rated. When using patch cords in the ceiling space, it is essential to verify that the entire patch cord complies with UL 2043, including the cable and the RJ45 plugs on either end.

Industry Cabling Standards: Setting the Bar on Performance

The ANSI/TIA-568 suite of commercial building telecommunications cabling standards, along with its international equivalent ISO/IEC 11801, details key specifications such as insertion loss, return loss, crosstalk, and resistance that impact transmission performance. Specifically, ANSI/TIA-568.2, *Balanced Twisted-Pair Telecommunications Cabling and Components*, defines connecting hardware requirements for a mated RJ45 connection. Several standards for specific types of facilities reference the ANSI/TIA-568 standards, including data centers (ANSI/TIA-942), industrial (ANSI/TIA-1005), healthcare (ANSI/TIA-1179), and educational (ANSI/TIA-4966). Similarly, ISO/IEC standards for various premises reference ISO/IEC 11801.

TIA-568.2 and ISO/IEC 11801 standards ensure interoperability among different manufacturers' products and classify performance categories and classes based on maximum data rates and bandwidth as follows:

- **Category 3 (Class C):** Characterized up to 16 MHz to support 10BASE-T transmission systems
- **Category 5e (Class D):** Characterized up to 100 MHz to support 1000BASE-T transmission systems
- **Category 6 (Class E):** Characterized up to 250 MHz to support 1000BASE-T transmission systems
- **Category 6A (Class EA):** Characterized up to 500 MHz to support 10GBASE-T transmission systems

ANSI/TIA-568 standards also include recommendations for maintaining the performance of RJ45 connections during the termination of twisted-pair cables. The standard advises terminating according to manufacturer instructions or, in their absence, maintaining cable geometry as close as possible to the termination point of the connecting hardware. The maximum pair un-twist for Category 3 cable is 75 mm (3 in.), and the maximum pair un-twist for Category 5e, Category 6, and Category 6A is 13 mm (0.5 in). Additionally, ANSI/TIA-568 standards specify T568A or T568B pin-pair assignments for terminating RJ45 connectors to four-pair cables, recommending uniform pin-pair assignments throughout installations (see Figure 6).

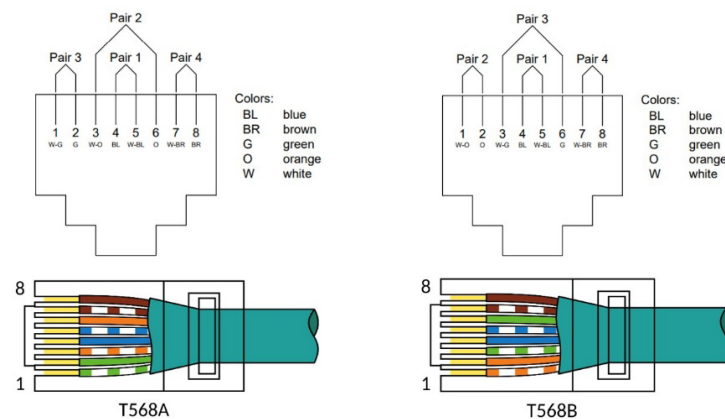

Figure 6: Eight-position jack pin-pair assignment T568A and T568B

RJ45 connectivity that does not comply with ANSI/TIA-568 standards can severely degrade network performance, leading to high bit error rates that cause dropped packets, reduced throughput and speed, and intermittent connectivity. These issues can be catastrophic for mission-critical applications, resulting in service disruptions, monetary losses, and even loss of life.

Due Diligence: The Best Defense Against Substandard RJ45s

Anyone involved in specifying, purchasing, or installing RJ45 connectivity must be aware of the risks associated with non-compliant products. The market is flooded with numerous unfamiliar, low-cost brands that may not comply with industry standards, some of which may be counterfeit. With higher frequencies, application speeds, and PoE levels becoming more prevalent, ensuring high-quality, compliant RJ45 connectivity is more crucial than ever.

While signal degradation and loss can lead to costly downtime for any business, the risks are far beyond that. Non-compliant RJ45 connectivity can pose a significant threat to property and even human life. Consider the widespread use of RJ45 connectivity across various critical sectors, including patient monitoring in healthcare, first responder communications, and essential infrastructure for power, water, and transportation. In one instance, non-compliant RJ45 connectivity was even responsible for an outage in an air traffic control system.

Integrators who deploy non-compliant RJ45 connectivity could face legal consequences. Purchasing or installing such connectivity can lead to building code violations, lawsuits, or even substantial fines or jail time in some jurisdictions. Furthermore, there is a risk of civil liability if non-compliant RJ45 connectivity causes a fire, resulting in property damage or loss of life. Property owners, building occupants, or even affected families could pursue civil suits based on negligence, fraud, or breach of contract and warranty.

Unfortunately, it is virtually impossible to determine if RJ45 connectivity uses non-compliant materials or out-of-spec dimensions without specialized equipment, such as precision vision systems, advanced measurement devices, and elaborate laboratory setups typically found in manufacturing and third-party testing labs. Plus, any RJ45 connectivity vendor can claim compliance. So how can Integrators deploying communications systems protect themselves?

The most effective way to mitigate risk is to purchase connectivity from known, reputable sources with an industry track record of delivering quality, standard-compliant products and comprehensive product documentation proving compliance. You can also look for components certified by performance verification programs, such as UL 3992 Outline of Investigation, which verifies the electrical characteristics, power delivery, mechanical aspects, materials, and performance of patch cords terminated to RJ45 connectors, with reference to standards like TIA-1096-A and ANSI/TIA 568.2.



How CCCA is Addressing Non-Compliant RJ45 Connectivity

Those who design, install, and use structured cabling systems have a right to expect uncompromised quality, performance, and safety. Non-compliant and substandard cable and connectivity products are eroding that right and pose a health and safety risk in today's increasingly digital society. While the majority of these non-compliant components are sold via lesser-known online distributors, ultimately, it is the purchaser and Integrator who bear the responsibility for the product. Thus, anyone who uses structured cabling must be aware of what they are installing, aware of the risks of using non-compliant components, and understand how they could be liable if something goes wrong.

The Communications Cable and Connectivity Association (CCCA) leads the fight to confront counterfeit and non-compliant ICT products. Through testing programs, educational initiatives, and screening tools, CCCA alerts and educates the industry on the dangers of counterfeit cable and, more importantly, how to avoid being misled by deceptive labels and marketing practices. CCCA's anti-counterfeiting efforts include close collaboration with independent testing agencies, U.S. Customs, and law enforcement. CCCA is also proactive within North American codes and standards bodies and other trade, industry, and governmental associations and organizations to communicate and influence policy and decisions affecting the quality, performance, and societal needs of cabling infrastructure.

The CCCA's New Technology & Trends Committee serves as a resource for well-researched, fact-based information and education on issues and technologies vital to the structured cabling industry. This committee encompasses several experts from CCCA member companies, including leading cable and connectivity manufacturers, distributors, and material suppliers. As part of their mission, this committee examines trends and technologies in the industry, identifies their broad industry implications, and recommends education outreach strategies to empower the ICT community.

CCCA member companies: Alphagary, Belden, Cable Components Group, Chemours, CommScope, Daikin America, Dow, Graybar, Legrand, Leviton Network Solutions, Optical Cable Corporation, Proterial Cable America, Prysmian Group, Quabbin Wire and Cable Co., Reelex Packaging Services, Sentinel Connector Systems, Superior Essex, Teknor Apex, VoltServer Digital Electricity, Wesco, Westlake Global Compounds, Wonderful High Tech.

Note: This article was published in the 2026 Jan-Feb-March Issue of BICSI's ICT Today Magazine.

© 2025 CCCA
1001 Pennsylvania NW, Washington, DC, 20004

For further information, visit the CCCA website [at www.cccassoc.org](http://www.cccassoc.org) or contact David Kiddoo, Executive Director, at dkiddoo@cccassoc.org or by phone at +1.410.353.3989. .